

IRT 3 PrepCure & IRT 4 PrepCure

These dryers are ideal for curing small to medium-sized surfaces. The products are used to speed up drying of putty, filler, base and clear coat. Using two manual timers, the products are very easy to use.

- 3 kW cassette
- Unique possibilities for positioning the cassettes
- Gold-coated FreeForm reflectors for optimal heat distribution
- Two manual timers:
 - Flash-off 50% output power
 - Full bake 100% output power
- Very easy to use
- Can cure all paint materials
- Efficient particle filter on the cassettes
- Powerful ventilation that cools the cassette and increases lamp life
- Maximum cassette height (IRT 3) 1,300 mm horizontal
- Maximum cassette height (IRT 4) 2,150 mm horizontal



Even the smallest Hyperion models are very efficient



The smaller Hyperion models have the same high quality as the advanced IRT dryers, but are somewhat simpler as regards function and design.

Common characteristics for all Hyperion dryers:

- Short-wave lamps
- Gold-coated FreeForm reflectors
- Powerful ventilation
- Increased heat propagation
- Even heat distribution
- Large drying areas



IRT 3 PrepCure and IRT 4 PrepCure

are ideal for use in the prep station. Both are equipped with a compact cassette that is controlled by two manual timers – Flash off up to 30 minutes, Full bake up to 30 minutes. The cassette is balanced with a gas-filled damper and can easily be operated with one hand. With IRT 4 PrepCure, you can reach a height of 2,150 mm, enabling curing of car roofs on high cars.

Curing areas

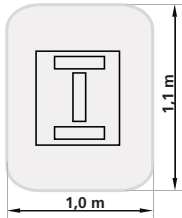

IRT 3 PrepCure

IRT 4 PrepCure

One cassette at a distance of 600 mm, on black sheet metal

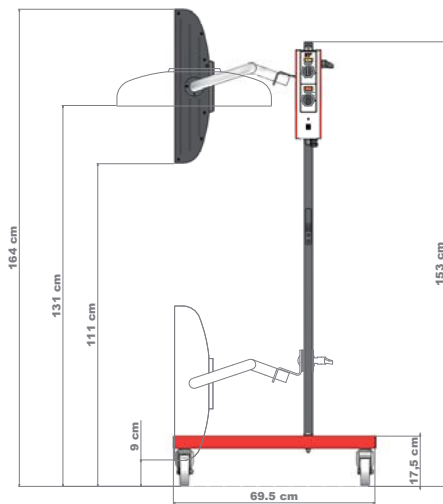

IRT 3 PrepCure

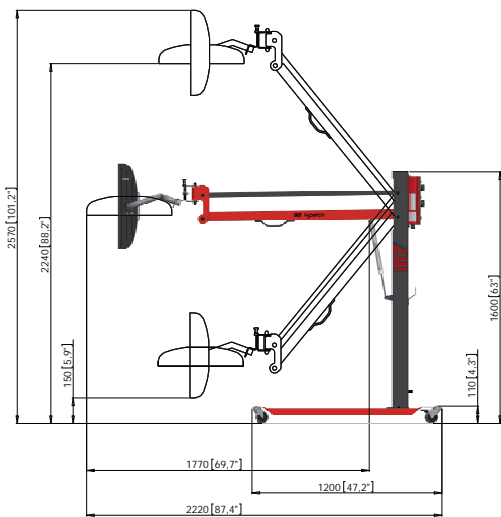

IRT 4 PrepCure

Short-wave for most efficient curing

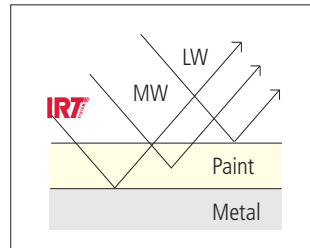

Simplified diagram. Short-wave heat cures from the inside and out, while medium-wave, long-wave and hot air primarily cure the surface.

All IRT dryers use short-wave technology. This, together with the unique IRT FreeForm reflectors, provides the best heat transfer possible. Short-wave IR has several other advantages. It is easy to control, provides full heat immediately and penetrates deep into the paint. The paint cures from the inside and out without retaining solvents and moisture that gives rise to problems with quality. Heat losses to the air are minimal and all energy is transferred to the surface to be dried.

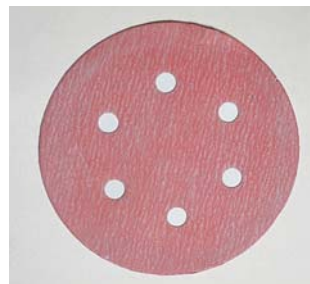

After only 3 minutes' curing with an IRT-4-1 PcAuto, you can polish with perfect results.



Despite a longer curing time with other products, only the surface is cured and the polishing tool becomes clogged.

Curing times

Minutes

| | |
|-----------------------|-------|
| Putty | 2-3 |
| Filler | 3-7 |
| Primer | 5-8 |
| Water-base paint | 2-4 |
| Base coat | 4-8 |
| Top coat | 6-10 |
| Clear coat | 5-10 |
| Filler on plastic | 7-10 |
| Top coat on plastic | 15-18 |
| Clear coat on plastic | 15-18 |

The curing times are extremely short. The times above apply to the IRT PcAuto series. Add a minute or two for other models

Electrical Data

| | IRT 3 PrepCure | IRT 4 PrepCure |
|----------------|----------------|----------------|
| Voltage | 220V 1 Ph | 220V 1Ph |
| Current | 13 A | 13 A |
| Output power | 3 kW | 3 kW |
| NEMA Plug Type | 6-20P | 6-20P |