

PRODUCT FACTS

IRT-300



Field of application

IRT's mobile paint dryers are professional tools for all types of paint shops. They are best suited for small to medium-sized repairs with all types of paint materials.

Characteristics

IRT's distinctive quality is its very high drying capacity, i.e. large and evenly dried areas in a short time. Moreover, they are extremely user friendly and control the drying process exactly to obtain the best results.

Technical description

IRT-300 is equipped with one or two compact cassettes. Each cassette is composed of three IRT short wave lamps and a cooling ventilator. The lamps are fixed in reflector bodies which are coated with gold for best heat distribution.

All the dryers are fitted with Optimal Curing Function which pulsates the energy and provides for the right amounts of energy at all stages of the drying process.

The interactive display gives clear information in several languages and it is possible to select from a number of ready-to-use drying programmes. Times and power levels for evaporation as well as curing are pre-programmed into the dryer's microprocessor. A feature of the IRT-300 is that it is easy to create drying programmes which match individual requirements.

All the IRT paint dryers are stable, easily-manoeuvred and have a long reach.

The cassettes are balanced by means of a gas spring and are easily adjusted with just one hand.

The IRT paint dryers have CE-approval.



IRT-System is the trademark for a complete drying programme developed by Hedson Technologies AB. It comprises everything from hand tools to large industrial installations. The company operates throughout the world and within several different product areas. Ever since it was founded over 30 years ago, Hedson Technologies AB has been a pioneer and leader within the IR-area. Our quality and environmental systems are certified in accordance with ISO 9001 and ISO 14001.

Technical description, IRT-300

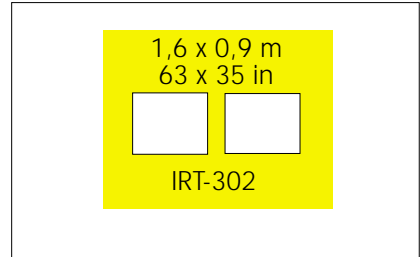
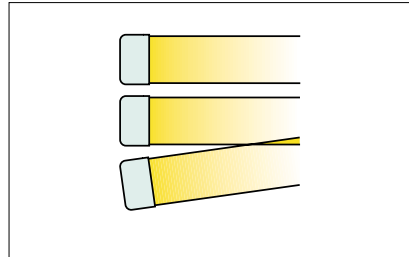
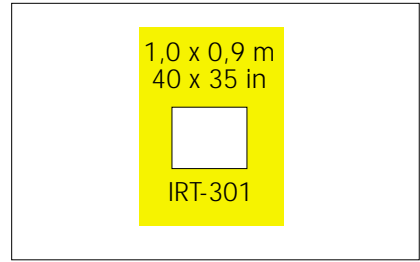
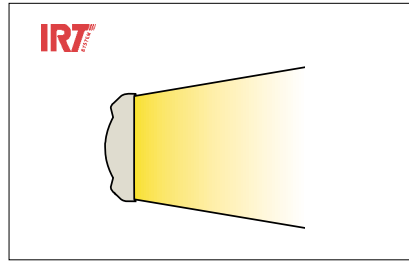
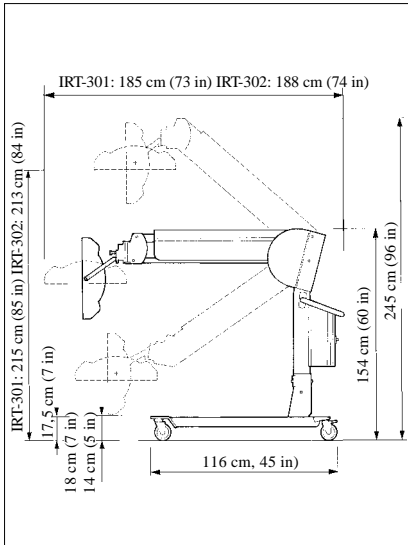

Packing

IRT-301

3 parcels, 0,8 m³ (14 cuft), ~60 kg (132 lb)

IRT-302

4 parcels, 1,1 m³ (18 cuft), ~68 kg (150 lb)

To ensure that the heat distribution is even, the IRT lamps are rigidly set in a compact, easily adjustable cassette. With many individual heat lamps, there is a big risk that one area may become overheated and another under-cured.

The cassette size is compact. Using a patent pending reflector solution, a drying area, several times larger than the cassette is obtained with unrivalled temperature evenness. Area measured on dark colour.

	IRT-301	IRT-302
No. of cassettes / lamps	1 / 3	2 / 6
Power, kW	3	6
Dried area, m (in)	1.0x0.9 (40x35)	1.6x0.9 (63x35)
Drying capacity, m ² /h (sqft/h)	12 (129)	19 (204)
Working distance, m(in)	0.5-0,7 (20-28)	0.5-0,7 (20-28)
Built in drying programmes	6	6
Installation of own times	3	3
Optimal Curing Function	x	x
Flash-off/curing energy levels	2	2
Automatic time control	x	x
Main cable, m (ft)	5 (17.5)	5 (17.5)

Putty	3 - 4 mins.
Filler	4 - 7 mins.
Primer	6 - 9 mins.
Base-coat	5 - 9 mins.
Top-coat	7 - 11 mins.
Clearcoat	6 - 11 mins.

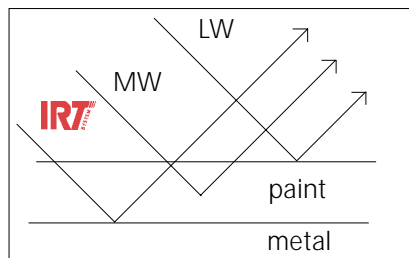

Electrical data:

IRT-301

230V, 1Ph, 13A, 3 kW
 230V, 3Ph, 8A, 3 kW
 400V, 3Ph, 4A, 3 kW

IRT-302

230V, 1Ph, 26A, 6 kW
 230V, 3Ph, 15A, 6 kW
 400V, 3Ph, 8A, 6 kW

The drying times are extremely short. The above-mentioned times are applicable for 2-pac material. Times and power levels for the most common paint materials are pre-programmed in the control unit.

Principle: Short wave IR works from the inside out. The heat penetrates all the way through to the sheet metal. Medium wave does not reach any further than the middle of the paint material and the heat from a long wave dryer or a heated oven stops at the surface.

The manufacturer reserves the right to change product design and specifications without prior notice.

Hedson Technologies AB and IRT-System are registered trademarks.
 © HEDSON TECHNOLOGIES AB, 2000



HEDSON TECHNOLOGIES AB
 Tel. +46 521-28 10 00
 Fax +46 521-669 09
 www.hedson.se

