



IRT 3-1 PcD & IRT 3-2 PcD

Standard dryers for all types of workshops. They are mostly used for small to medium-sized repairs and for primers, but have sufficient output to cure all kinds of paint materials.

- One (3 kW) or two (6 kW) cassettes depending on desired drying surface
- Unique possibilities to position the cassettes
- Gold-coated FreeForm reflectors for optimal heat distribution
- Computerised curing process
- Electronic distance sensor
- Very easy to use
- 12 preset and 3 custom programs
- Can cure all paint materials
- Smart stand design
- Efficient particle filter on the cassettes
- Powerful ventilation that cools the cassette and increases lamp life
- Maximum cassette height 88.5" (horizontal), 100" (vertical)

We are setting a new standard with IRT Hyperion PcD

FreeForm reflectors

With the introduction of the new, gold-coated, asymmetric FreeForm reflectors, we have developed the reflectors of the future. Increased heat distribution provides a more even heat distribution implying that a larger area can be cured during the same period. A lot of energy is saved by only irradiating the object and not heating up the surrounding air. All cables from the stand to the cassettes are enclosed. You avoid loose cables that can be burned or cause scratches in the paint, leaving your hands free to move the dryer.



Cassette/lamps

There are two things that shorten the service life of an IR lamp: overheating and dust. An IRT lamp should last for 20,000 operating hours. For this reason, the Hyperion cassettes are equipped with powerful ventilation cooling both lamps and cassettes. This extends the life of the lamps significantly. The problems with dust have been resolved with a new, effective particle

filter on the rear of the cassette. The software informs the operator of how much cleaning capacity is left in the particle filter and when it is time for the next filter replacement.

Stand

Thanks to the special angle of the arm and the advanced design of the foot, curing is possible in places that were previously inaccessible. IRT Hyperion reaches higher than any other mobile dryer, 88.5" (2,250 mm) with the cassette in the horizontal position and approx. 100" (2,550 mm) in the vertical position.

The new smart foot design even allows it to get under low cars and it is possible to place the mobile dryer around a wheel.

The mobile unit's large and well-balanced wheels roll unhindered over floor gratings and easily cope with air hoses and other obstacles on the workshop floor.



Control unit

The functions are easy to understand and use – **even on the most advanced models**. There is a program for each drying requirement. It is started with the simple press of a button.

18 different languages can easily be set. The display is clear and its brightness can be regulated.

The ultrasound sensor measures the distance and signals when the distance is correct.

The temperature is continuously measured, while the microprocessor regulates the effective output upwards or downwards in a split second for optimal curing results.

As an operator, you can continuously monitor the curing process and receive information about such things as object temperature and elapsed/remaining program time.

Start the control unit, select a program then dry.

Curing areas

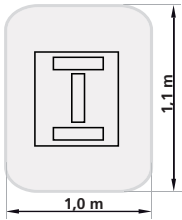

IRT 3-1 PcD

One cassette at a distance of 600 mm, on black sheet metal

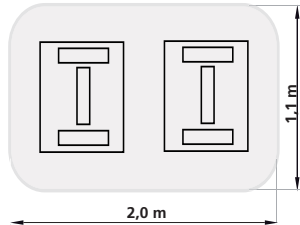

IRT 3-2 PcD

Two cassettes at a distance of 600 mm, on black sheet metal

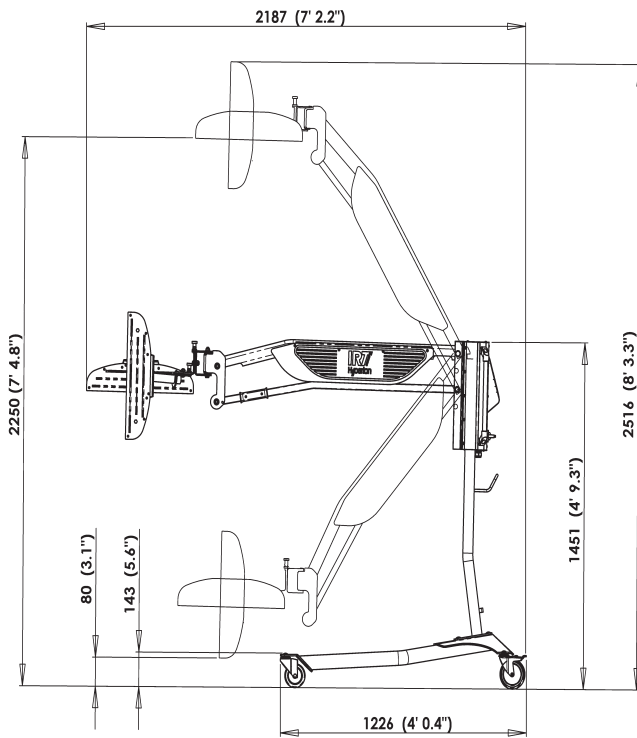

IRT 3-1, 3-2 PcD

Short-wave for most efficient curing

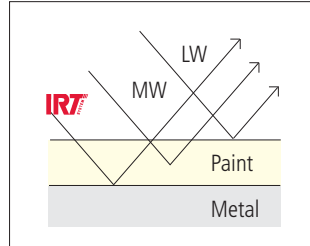

Simplified diagram. Short-wave heat cures from the inside and out, while medium-wave, long-wave and hot air primarily cure the surface.

All IRT dryers use short-wave technology. This, together with the unique IRT FreeForm reflectors, provides the best heat transfer possible. Short-wave IR has several other advantages. It is easy to control, provides full heat immediately and penetrates deep into the paint. The paint cures from the inside and out without retaining solvents and moisture that gives rise to problems with quality. Heat losses to the air are minimal and all energy is transferred to the surface to be dried.

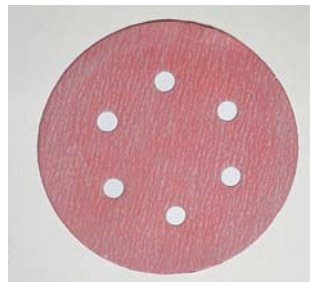

After only 3 minutes' curing with an IRT-4-1 PcAuto, you can polish with perfect results.



Despite a longer curing time with other products, only the surface is cured and the polishing tool becomes clogged.

Curing times

	Minutes
Putty	2-3
Filler	3-7
Primer	5-8
Water-base paint	2-4
Base coat	4-8
Top coat	6-10
Clear coat	5-10
Filler on plastic	7-10
Top coat on plastic	15-18
Clear coat on plastic	15-18

The curing times are extremely short. The times above apply to the IRT PcAuto series. Add a minute or two for other models

Electrical Data

	IRT 3-1 PcD	IRT 3-2 PcD
Voltage	220V 1 Ph	220V 1Ph
Current	13 A	26 A
Output power	3 kW	6 kW
NEMA Plug Type	6-20P	6-30P